



RAASM MOBILE COMBINATION OIL SUCTION AND DRAINER UNIT

The RAASM Oil Drainer and Extractor for vehicles is one of the most sought-after oil drainers in the market. These are gravity drainers with pantographs and on a pit built for draining oils from cars and other medium-sized vehicles.

These easy-to-use oil draining and extracting devices come with a 100-liter tank as well as an inspection bowl that has a capacity of 8 liters. They can be easily carried around the workshop as well due to a 4-wheel mount at the bottom.

NOTE: Item supplied in 3 boxes.

FEATURES & BENEFITS:

- Drains and extracts waste oil from cars & light commercial vehicles
- Anti-splash screen filter
- Holding tank of 98L
- Removable Tool tray
- Available in 65L and 90L capacity
- Drain bowl capacity of 15L
- Level Indicator in liters and gallons
- Supplied with 6 probes

SPECIFICATIONS:

Bowl capacity	15 L
Noise level	75 dB
Discharging/Suction hose	2 m / 2 m
Max pressure for discharging	0.5 bar



AF-RA-44091

PART NO.		TANK CAPACITY	MAX DRAINING CAPACITY	WEIGHT
AF-RA-44060	RAASM 65L Mobile Combination Oil Suction and Drainer Unit	65 L	52 L	34.6 Kg
AF-RA-44090	RAASM 90L Mobile Combination Oil Suction and Drainer	90 L	75 L	38.2 Kg
AF-RA-44091	RAASM 90L Mobile Comb Oil Suction Drainer Unit w/ Prechamber *	90 L	75 L	42,1 kg

* Gravity and suction drainer, 90 litres with transparent prechamber and suction probe kit.



RAASM MOBILE COMBINATION OIL SUCTION AND DRAINER UNIT

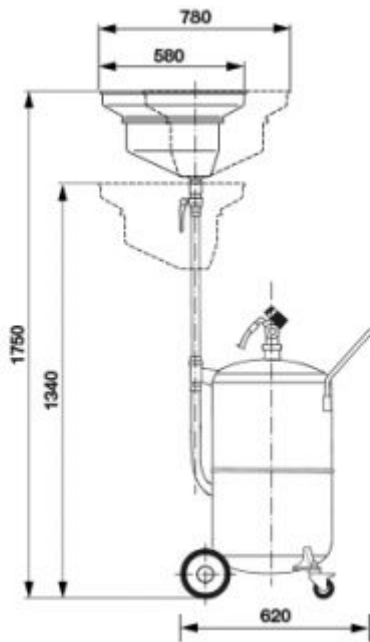

AF-RA-44060

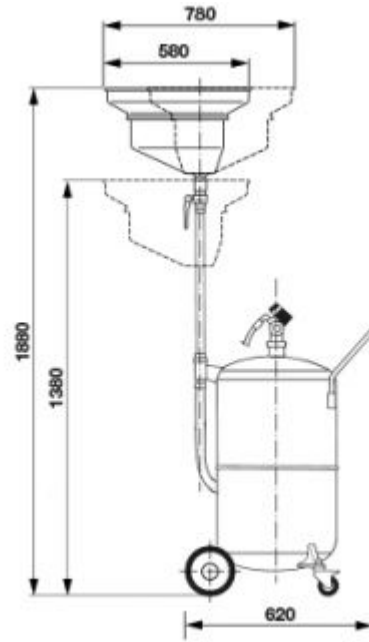

AF-RA-44090

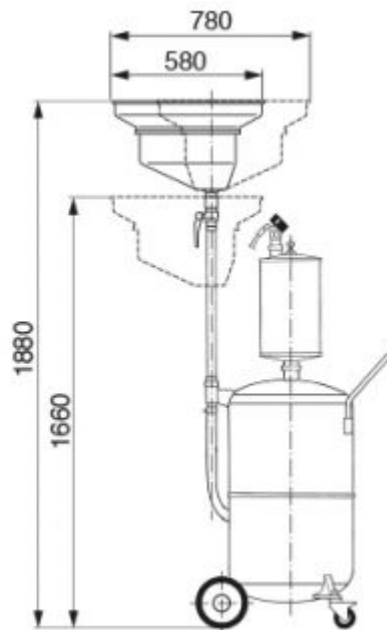

AF-RA-44091